



REVOLUTION
RACE CARS

Arrive & Drive Race Drive Proposal

2025

Events :

Revolution Cup North America

Arrive and Drive

Arrive and drive services
provided by Certified Dealer
Classic Car Club



2025 Revolution Cup

Now entering its third year competing in the well-established Prototype Sprint Series Association (PSSA), the Revolution Cup, open to all Revolution models, will feature its own points system and championship within the PSSA.

The 2025 Revolution Cup will consist of a six-weekend championship, with two sprint races and a one-hour endurance race per weekend, at some of the most prestigious venues across North America. Revolution Race Cars has carefully selected six race weekends within the PSSA, purposefully balancing events across the East Coast, West Coast, and Central North America to ensure accessibility for teams and drivers from all regions.

The championship will be determined based on each driver's top 15 results out of the 18 races, allowing participants to drop their three lowest-scoring races. This system accommodates potential logistical challenges or an unlucky race weekend, ensuring fairness for all competitors.



MAR
20-23 MICHELIN RACEWAY
ROAD ATLANTA

APR
24-27 SONOMA
RACEWAY

MAY
02-04 WEATHERTECH
RACEWAY LAGUNA
SECA

JUN
26-29 ROAD
AMERICA

SEP
04-07 WATKINS GLEN
INTERNATIONAL

OCT/NOV
30-02 CIRCUIT OF
THE AMERICAS





#SUPERCHARGED

The car : Revolution 500SC

- A-One 500SC
- BHP : 500
- Top Speed : 285 km/h
- 100 – 200 km/h : 5.7s
- Weight: 834kg





500 EVO

EVO upgrades are set out to achieve the following:

- Improved mechanical/low-speed grip
- Refinement of engine power delivery characteristics
- Improved aerodynamic efficiency and balance adjustment
- Stronger and more adjustable transmission

The 500 EVO was:

Targeted to run 1.5 to 2 seconds per lap faster than the 500SC, whilst also improving reliability and consistency over longer race distances.

The 500 EVO debuted at Silverstone on February 20th, 2024:

Won debut race at Zandvoort in April, clearing even the LMP3 cars by over a second per lap!

The first truly affordable sports racer with a carbon safety cell and cutting-edge technology

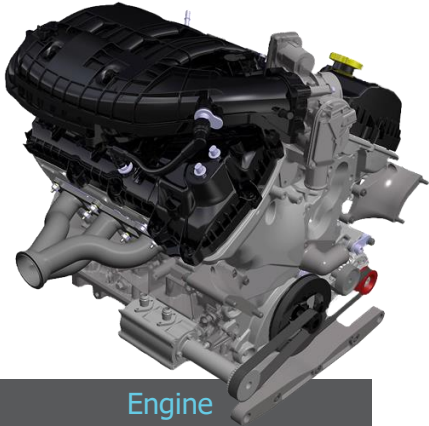

Engine

Developed from a Ford-based V6 unit, the Revolution A-One engine has proven reliability to match its high-end performance.

Tuned and prepared for high-energy track work, the power unit is one of the many highlights of this car, with a large torque spread and an epic soundtrack. It also has the reliability, easy servicing and long refresh intervals.

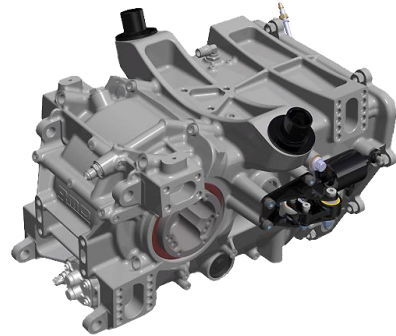

Gearbox

Mated to the engine is a bespoke 6-speed paddle shift gearbox built by 3MO.

With lightning-fast up-shifts and perfectly blipped down-shifts, it's casing is loadbearing, with the suspension mounted directly onto it.

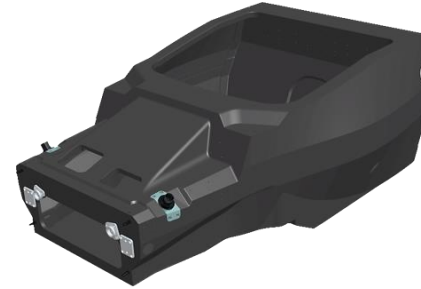

Chassis

The FIA-approved carbon safety cell is both reassuringly strong and spacious enough to fit the largest of drivers and passengers.

It is created by an infusion process developed by DD Composites that keeps the manufacturing costs low but the quality high.

It's also fitted with the world's first double halo system ensuring the highest levels of occupant protection.



Suspension

Double-wishbones meet inboard dampers and adjustable anti-roll bars front and rear.

The dampers are three-way adjustable and have been developed specifically for the A-One.

It will out-handle anything in its class and has been described by very experienced pro-drivers as the best car they've ever driven.

To reduce running costs and spares requirements, components such as the uprights and rockers are identical at each corner.



Control Centre

The Revolution F1-style steering wheel is a piece of art.

Manufactured in carbon, the steering wheel features multiple push and rotary buttons for easy control of engine performance, traction control and brake bias, with ideally-placed buttons for comms, the pit lane speed limiter, data markers and much more.

The wheel centre displays all the required driving information in multiple formats to match every driver's preferences. Full downloadable video data analysis is also available.



Double-halo : another Revolution first

Exceeding FIA standards, the double-halo head protection is inspired by that mandated in Formula One



“The closest car I’ve driven to a Le Mans Prototype car!”

Sir Chris Hoy

- 2015 LMP3 Champion
- Le Mans 24-hour driver
- Six-time Olympic champion
- Eleven-time World champion



March Road Atlanta

- 9 x test sessions
- 2 x quali
- 2 x PSSA 30 min sprint races
- 1 x 60 min Enduro
- 1 x No. 1 mechanic (dedicated)
- 1 x No. 2 mechanic (shared)
- 1 x Data engineer (shared)
- 1 x Driver coach (shared)
- 2 sets new slicks included
- Serviceable wets supplied if necessary
- Damage not included. Charged as necessary
- **\$26,750 Total**

April Sonoma

- 9 x test sessions
- 2 x quali
- 2 x PSSA 30 min sprint races
- 1 x 60 min Enduro
- 1 x No. 1 mechanic (dedicated)
- 1 x No. 2 mechanic (shared)
- 1 x Data engineer (shared)
- 1 x Driver coach (shared)
- 2 sets new slicks included
- Serviceable wets supplied if necessary
- Damage not included. Charged as necessary
- **\$28,750 Total**



May Laguna Seca

- 9 x test sessions
- 2 x quali
- 2 x PSSA 30 min sprint races
- 1 x 60 min Enduro
- 1 x No. 1 mechanic (dedicated)
- 1 x No. 2 mechanic (shared)
- 1 x Data engineer (shared)
- 1 x Driver coach (shared)
- 2 sets new slicks included
- Serviceable wets supplied if necessary
- Damage not included. Charged as necessary
- **\$28,750 Total**



June Road America

- 9 x test sessions
- 2 x quali
- 2 x PSSA 30 min sprint races
- 1 x 60 min Enduro
- 1 x No. 1 mechanic (dedicated)
- 1 x No. 2 mechanic (shared)
- 1 x Data engineer (shared)
- 1 x Driver coach (shared)
- 2 sets new slicks included
- Serviceable wets supplied if necessary
- Damage not included. Charged as necessary
- **\$27,000 Total**

August Watkins Glen

- 9 x test sessions
- 2 x quali
- 2 x PSSA 30 min sprint races
- 1 x 60 min Enduro
- 1 x No. 1 mechanic (dedicated)
- 1 x No. 2 mechanic (shared)
- 1 x Data engineer (shared)
- 1 x Driver coach (shared)
- 2 sets new slicks included
- Serviceable wets supplied if necessary
- Damage not included. Charged as necessary
- **\$25,000 Total**



October COTA

- 9 x test sessions
- 2 x quali
- 2 x PSSA 30 min sprint races
- 1 x 60 min Enduro
- 1 x No. 1 mechanic (dedicated)
- 1 x No. 2 mechanic (shared)
- 1 x Data engineer (shared)
- 1 x Driver coach (shared)
- 2 sets new slicks included
- Serviceable wets supplied if necessary
- Damage not included. Charged as necessary
- **\$30,000 Total**



Season offer

- 6 Revolution Cup events, \$166,250
- Discount to pay in advance \$150,000
- Normal consumables included, excessive wear and damage repairs are charged extra



Contact :

nigel@revolutionracecars.com

or

zacm@classiccarclub.com

Nigel mobile: + 44 (0) 7818 047 866

Zac mobile : +1 646 331 8224