

Arrive & Drive Proposal

Events :

**2025 Supercar Challenge
Season**



REVOLUTION
RACE CARS



24-7 Motorsport

- **24-7 Motorsport** is the official **Revolution Factory Certified Arrive-and-Drive Race Team** for Europe. As a result, all Revolution factory arrive-and-drive services are delivered exclusively through 24-7 Motorsport.
- 24-7 Motorsport prides itself on delivering unbeatable customer service at competitive prices—both on and off the circuit.
- The team's goal is to meet every driver's needs by offering top-quality services and tailored solutions that provide real value. This enables drivers to maximize their time in the car without worrying, confident that every detail has been expertly handled.
- 24-7 Motorsport has operated an LMP3 program in Europe for many years, making them an ideal team for prototype drivers.



- The **Supercar Challenge powered by Hankook** is organised and promoted by **V-Max Racing Management** based in Breda.
- In recent years, over 175 races have been held at major events on numerous circuits, including the Dutch venues **Circuit Zandvoort** and **TT Circuit Assen**. The series has also ventured across borders to prestigious tracks such as **Circuit Zolder** and **Spa-Francorchamps** in Belgium; **Nürburgring**, **Hockenheim**, **Oschersleben**, and **Eurospeedway Lausitzring** in Germany; and **Silverstone**, **Donington Park**, **Brands Hatch**, **Rockingham**, and **Snetterton** in England.
- The Supercar Challenge features a mix of **GT** and **prototype race cars**, with race durations ranging from 60 to 120 minutes. This format makes it an ideal series for **two-driver teams**, showcasing exciting action at premier circuits.



2025 Calendar

- April 4-5-6 - **Zandvoort**
 - 2 x 20 min quali, 2 x 30 min races & 1 x 60 min race
- May 31 June 1 – **Spa Francorchamps**
 - 2 x 20 min quali & 2 x 60 min races
- July 11-12-13 - **Zolder**
 - 2 x 20 min quali & 2 x 60 min races
- August 8-9-10 - **Assen**
 - 2 x 20 min quali & 2 x 60 min races
- September 26-27-28 - **Zandvoort**
 - 2 x 20 min quali & 1 x 120 min races
- October 24-25-26 - **Assen**
 - 2 x 20 min quali & 2 x 60 min races

Revolution 427

- A-One 427
- BHP : 427
- Top Speed : 255 km/h
- 100 – 200 km/h : 6.2s
- Weight: 820kg





#SUPERCHARGED

Revolution 500SC

- A-One 500SC
- BHP : 500
- Top Speed : 285 km/h
- 100 – 200 km/h : 5.7s
- Weight: 834kg





500 EVO

EVO upgrades are set out to achieve the following:

- Improved mechanical/low-speed grip
- Refinement of engine power delivery characteristics
- Improved aerodynamic efficiency and balance adjustment
- Stronger and more adjustable transmission

The 500 EVO was:

Targeted to run 1.5 to 2 seconds per lap faster than the 500SC, whilst also improving reliability and consistency over longer race distances.

The 500 EVO debuted at Silverstone on February 20th, 2024:

Won debut race at Zandvoort in April, clearing even the LMP3 cars by over a second per lap!

The first truly affordable sports racer with a carbon safety cell and cutting-edge technology

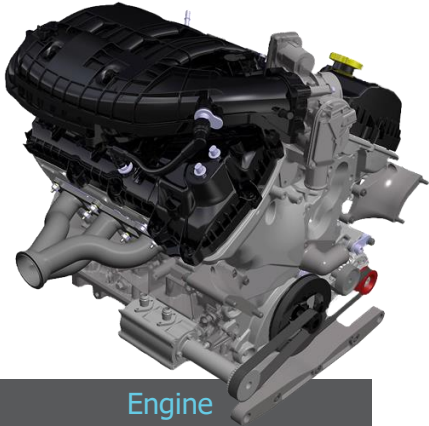

Engine

Developed from a Ford-based V6 unit, the Revolution A-One engine has proven reliability to match its high-end performance.

Tuned and prepared for high-energy track work, the power unit is one of the many highlights of this car, with a large torque spread and an epic soundtrack. It also has the reliability, easy servicing and long refresh intervals.

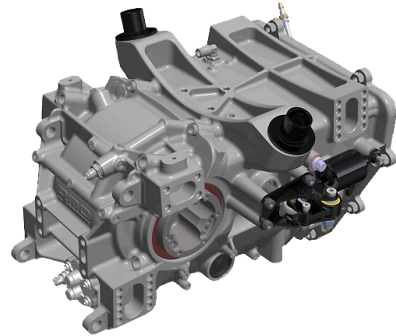

Gearbox

Mated to the engine is a bespoke 6-speed paddle shift gearbox built by 3MO.

With lightning-fast up-shifts and perfectly blipped down-shifts, it's casing is loadbearing, with the suspension mounted directly onto it.



Chassis

The FIA-approved carbon safety cell is both reassuringly strong and spacious enough to fit the largest of drivers and passengers.

It is created by an infusion process developed by DD Composites that keeps the manufacturing costs low but the quality high.

It's also fitted with the world's first double halo system ensuring the highest levels of occupant protection.



Suspension

Double-wishbones meet inboard dampers and adjustable anti-roll bars front and rear.

The dampers are three-way adjustable and have been developed specifically for the A-One.

It will out-handle anything in its class and has been described by very experienced pro-drivers as the best car they've ever driven.

To reduce running costs and spares requirements, components such as the uprights and rockers are identical at each corner.



Control Centre

The Revolution F1-style steering wheel is a piece of art.

Manufactured in carbon, the steering wheel features multiple push and rotary buttons for easy control of engine performance, traction control and brake bias, with ideally-placed buttons for comms, the pit lane speed limiter, data markers and much more.

The wheel centre displays all the required driving information in multiple formats to match every driver's preferences. Full downloadable video data analysis is also available.



Double-halo : another Revolution first

Exceeding FIA standards, the double-halo head protection is inspired by that mandated in Formula One



“The closest car I’ve driven to a Le Mans Prototype car!”

Sir Chris Hoy

- 2015 LMP3 Champion
- Le Mans 24-hour driver
- Six-time Olympic champion
- Eleven-time World champion

Arrive & drive includes

- Revolution Race Car rental (dedicated for season)
- 1 × No. 1 mechanic (dedicated)
- 1 × No. 2 mechanic (shared)
- 1 × Data engineer (shared)
- Race weekend entry fees
- Race fuel
- 3 or 4 sets of new slicks included per race meeting
- Wear & tear consumables
- Prep and re-prep of car
- Serviceable wets supplied if necessary
- Damage not included, charged as necessary
- Friday test not included, optional charge

2025 full season budget

427

- 6 x Race weekends £115,000
- 6 x Option Friday tests £12,000

500SC

- 6 x Race weekends £120,000
- 6 x Option Friday tests £14,000

500 EVO

- 6 x Race weekends £130,000
- 6 x Option Friday tests £17,000



Optional extras available on request

- Additional new slick or wet tyres
- Race insurance
- Driver coach
- Pre meeting simulator sessions
- Sponsorship wrap

24-7
MOTORSPORT

